

# Water Specialist EE Control Valve Programming Manual

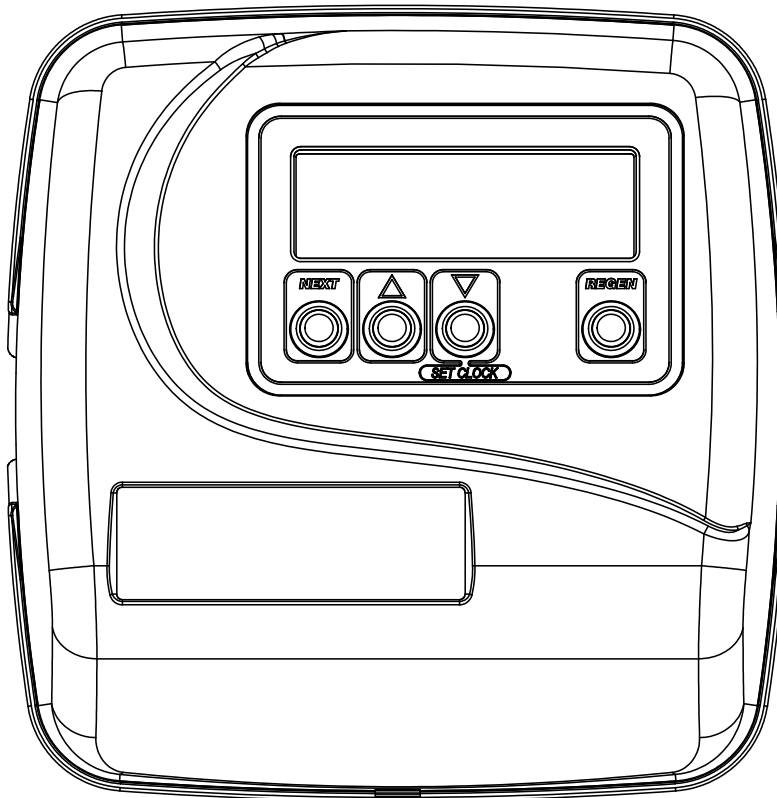



## Table of Contents

Front Cover and Drive Assembly .....	4
Regeneration and Error Screens.....	5
Button Operation and Function.....	5
User Displays .....	6
Configuration Settings .....	7
OEM Softener System Setup .....	11
Setting Options Table .....	13
OEM Filter System Setup .....	14
Installer Display Settings: 7 Day Regeneration .....	16
Installer Display Settings: 28 Day Regeneration / Auto .....	17
Diagnostics.....	18

### Front Cover and Drive Assembly

Drawing No.	Order No.	Description	Quantity
1	V3175EE-01	WS1EE FRONT COVER ASSEMBLY	1
2	V3107-01	WS1 MOTOR	1
3	V3002	WS1 DRIVE BRACKET ASY W/ MOTOR	1
4	V3408EE-05BOARD	WS1THRU2 EE5 20PIN PCB REPLC	1
5	V3110	WS1 DRIVE GEAR 12X36	3
6	V3109	WS1 DRIVE GEAR COVER	1
Not Shown	V3186-06	WS1 POWER SUPPLY US 15VDC HOCP	1
	V3186-01	WS1 POWER CORD ONLY	
Not Shown	V3178	WS1 DRIVE BACKPLATE	1

Refer to Control Valve Service Manual for other drawings and part numbers.

Relay Driver Output Type: Single Solid-State 12 VDC wet contact - N.O.

Relay Driver Output Capacity: 12 VDC @100 mA.

*Note:* Check for proper mounting dimensions on valve backplate prior to mounting an external relay under control cover.

We recommend that each externally wired relay contain a suppressor diode, which is normally placed across the relay coil in order to protect the control against back EMF at relay coil deactivation.

Power Supply	U.S.	International
Supply Voltage	100 – 120 VAC	100 – 240 VAC
Supply Frequency	50/60 Hz	50/60 Hz
Output Voltage	15 VDC	15 VDC
Output Current	500 mA	500 mA

Wiring For Correct On/Off Operation	
PC Board Relay Terminal Block	Relay
RLY 1	Coil -
COM	Coil +

When replacing the battery, align positives and push down to fully seat.

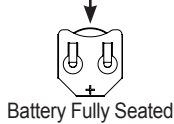

Correct Battery Orientation

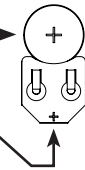

Battery replacement is 3 volt lithium coin cell type 2032.

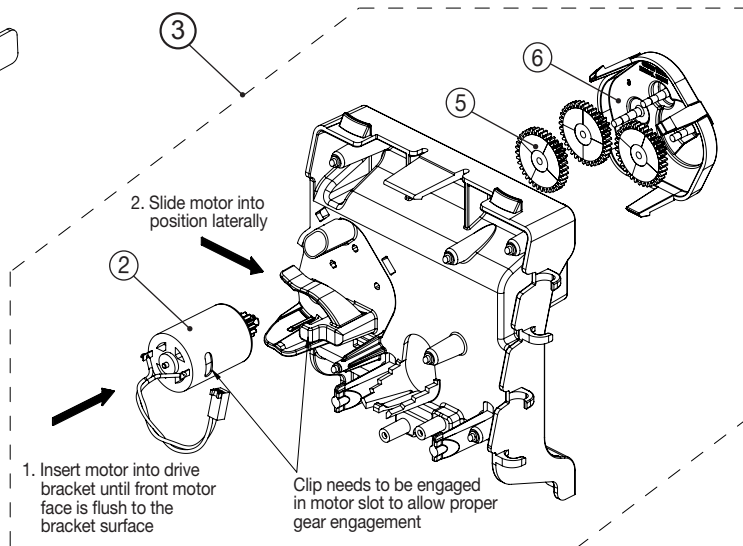
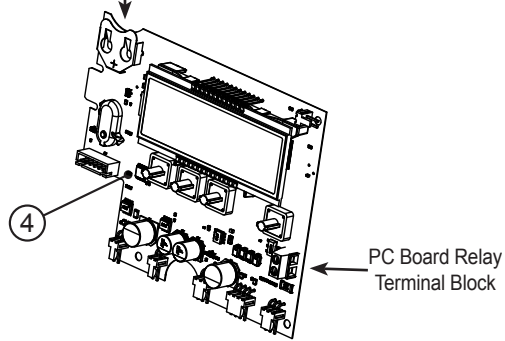
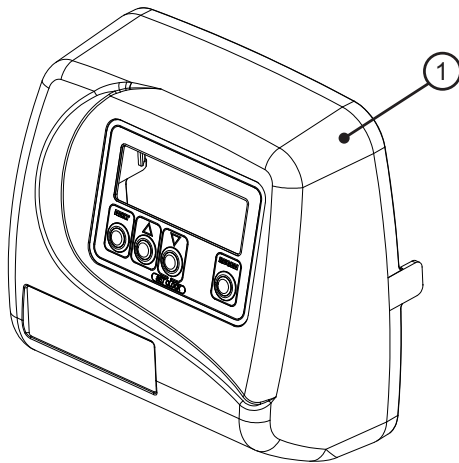

### Regeneration and Error Screens



**Regen Screen**

Displays the time remaining in the current cycle. Press REGEN to advance to the next cycle.



**Error Screen**

Alternated flashing Err and error code every 3 seconds. To clear, disconnect the power supply at the PC board and reconnect, or press NEXT and REGEN simultaneously for 3 seconds.



*REGEN Pndg* is displayed in alternator systems when a unit is waiting to initiate the first cycle step of regeneration.

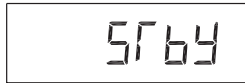

*Stby* is displayed in alternator systems when a valve is in standby mode.



*REGEN Pndg RINSE FILL* is displayed whenever a zero-capacity tank has transferred to an off-line state and is currently waiting to initiate the second portion of a regeneration cycle. Viewed only when Delayed Rinse and Fill is set to *ON*.

### Button Operation and Function



Scrolls to the next display.

Press and release once to schedule a regeneration at the preset delayed regeneration time.



Press and release again to cancel the regeneration.

Press and hold for at least 3 seconds to initiate an immediate regeneration.

Press while in regeneration to advance to the next cycle.

Press while in the program levels to go back to the previous display.

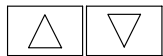

Changes variable being displayed.

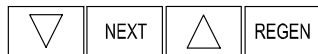

Key sequence to lock and unlock program settings.

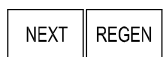

Hold for 3 seconds to initiate a control reset. The software version is displayed and the piston returns to the home/service position, resynchronizing the valve.



Used with valve type 1.0 T and 1.5T. Hold for at least 3 seconds to cause a switch in the tank in service without cycling the regeneration valve. After tank switch, days remaining and capacity remaining status is retained for each tank until the next regeneration.

**Table 1  
Regeneration Cycles and Times**

Cycle	Range		
	Softening	Filtering Regen	Filtering Backwash
Backwash	1 – 120 min or OFF	1 – 120 min or OFF	1 – 120 min or OFF
Regenerant Draw/Slow Rinse (UP or DN)	1 – 180 min or OFF	1 – 180 min or OFF	N/A
Fast Rinse	1 – 120 min or OFF	1 – 120 min or OFF	1 – 120 min or OFF
Regenerant Refill	0.1 – 200 lb or OFF	0.05 – 20 gal or OFF	N/A
Regenerant Refill for 2.0" or 1.5" set to <i>MIN</i> (softening only)	0.1 – 99 min or OFF	0.1 – 99 min or OFF	N/A
Service	1 – 480 min or OFF	N/A	N/A

The user can initiate manual regeneration. The user has the option to request the manual regeneration at the delayed regeneration time or have the regeneration occur immediately:

1. Press and release REGEN. *REGEN TODAY* will flash on the display and regeneration will occur at the delayed regeneration time. Press and release REGEN to cancel the request.
2. Press and hold REGEN for approximately 3 seconds to immediately start the regeneration. The user cannot cancel this request except by resetting the control by pressing NEXT and REGEN simultaneously for approximately 3 seconds.

## User Displays

### General Operation:

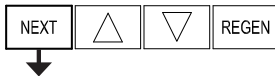
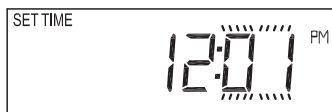
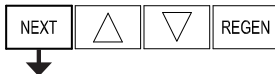
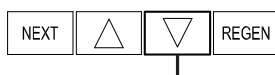
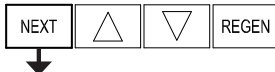
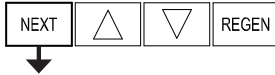
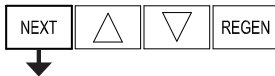
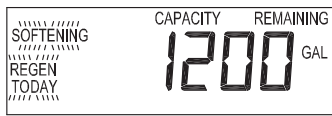

When the system is operating, one of 5 displays may be shown. Press NEXT to alternate between the displays shown below.

#### User 1

Typical user display. Shows volume remaining to regeneration. This screen will not be viewed if the control is set for time-clock operation.

#### User 2

Displays number of days to next regeneration.

#### User 3

Flow Rate.

Displays present flow rate.

This display will not appear if Step 5CS is set to *ALT A* or *ALT b* and the valve is currently in standby. If Step 2CS is set to *1.0T* or *1.5T*, the display will indicate the tank currently in Service (*A* or *b*) in the left-most digit.

#### User 4

Displays total volume in gallons since last reset. If a meter is not used, this display will show zero.

Press ▼ for 3 seconds to reset to 0.

#### User 5

Shows current time.

#### Setting Time of Day

Press NEXT until time of day is displayed. Then, press and hold ▼ until *SET TIME* is displayed and the hour flashes once. Press ▼ or ▲ until the correct hour is displayed.

Then, press NEXT. The minutes will flash. Press ▼ or ▲ until the correct minute is displayed.

Press NEXT to return to User displays. Time of day should only need to be set after power outages lasting more than 8 hours, if the battery has been depleted and a power outage occurs, or when daylight saving time begins or ends. If a power outage lasting more than 8 hours occurs, the time of day will flash, which indicates the time of day should be reset. If a power outage lasts less than 8 hours and the time of day flashes, the time of day should be reset and the battery replaced.

### Configuration Settings

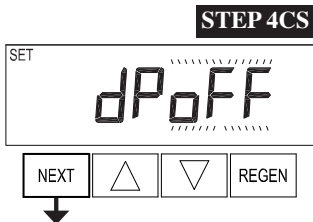
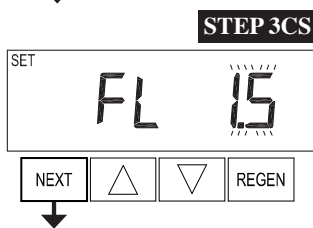
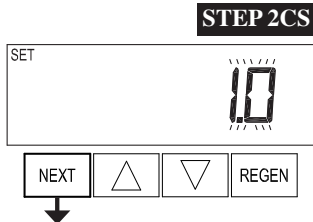
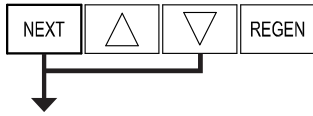

**Step 1CS** – Press NEXT and ▼ simultaneously for 5 seconds and release. Then, press NEXT and ▼ simultaneously for 5 seconds again and release. If screen in Step 2CS does not appear in 5 seconds, the lock on the valve is activated. To unlock, press ▼, NEXT, ▲, and REGEN in sequence, and try again.

**Step 2CS** – Valve Type: Use ▼ or ▲ to select 1.0 for 1" valve, 1.25 for 1.25" valve, 1.5 for 1.5" valve, 2.0 for 2" valve, 1.0T for 1.0" twin valve, or 1.5T for 1.5" twin valve. Press NEXT to go to Step 3CS. Press REGEN to exit Configuration Settings.

**Step 3CS** – Meter Size: Use ▼ or ▲ to select which size flow meter is to be used with the valve: 1.0r, 1.5, 2.0, or 3.0. Variable meter pulses of 0.1 – 150 PPG can also be selected. This display will only appear if Step 2CS is set to 1.5 or 2.0. Press NEXT to go to Step 4CS. Press REGEN to return to the previous step.

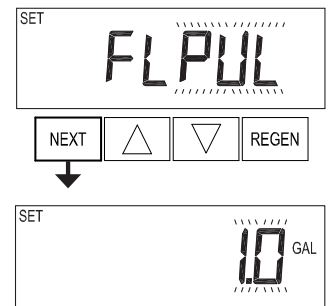

**Step 4CS** – Auxiliary Input: Allows for the use of an outside signal to control the initiation of a regeneration. Selection only needed if a connection is made to the 2-pin connector labeled DP SWITCH located on the printed circuit board. Use ▼ or ▲ to select one of the following options:

- *oFF*: Feature not used.
- *on0*: Regeneration will occur immediately if the dP switch is closed for 2 uninterrupted minutes. In a twin alternating system, the MAV will transition first to switch units so that the signaled unit can start regeneration. After the MAV has fully transitioned, the regeneration begins immediately. The Delayed Rinse and Fill feature will not be available for WS1 – WS1.5 control valves programmed for twin alternating if this option is selected.
- *dEL*: Regeneration will occur at the scheduled delayed regeneration time if the dP switch is closed for 2 uninterrupted minutes. In a twin alternating system, once the dP switch is triggered, the PC Board will display *REGEN TODAY*. At the delayed regeneration time, the control will switch tanks and the triggered unit will regenerate. The Delayed Rinse and Fill feature will not be available for WS1 – WS1.5 control valves programmed for twin alternating if this option is selected.
- *HoLd*: Regeneration will be prevented from occurring while the dP switch is closed. In a twin alternating system, the regeneration of a unit can be prevented upon switch closure. If the unit depletes the capacity down to zero, it will not be allowed to switch tanks to regenerate until the switch is open. The Delayed Rinse and Fill feature can be set in conjunction with this option if desired.

*Note:* In a twin alternating system each control must have a separate dP signal or dP switch. One dP signal or one dP switch cannot be used for both controls. Press NEXT to go to Step 5CS. Press REGEN to return to previous step.

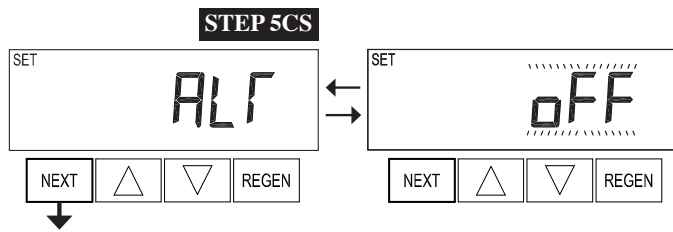

**Step 5CS – ALT MAV Output:** Use ▼ or ▲ to select one of the following options:

- *nHbP*: The control valve operates with a no hard water bypass.
- *SEPS*: The control valve has a separate source during the regeneration cycle.
- *SYS*: The control valve operates with a Clack system controller.
- *ALT A* or *ALT b*: The control valve acts as an alternator.
- *OFF*: None of these features are used.

This display will not appear if Step 2CS is set to *1.0T* or *1.5T*.

Only use Clack no hard water bypass valves or Clack motorized alternating valves (MAV) with these selections. Clack no hard water bypass valves (1" or 1.25" V3070FF or V3070FM) are not designed to be used with the Alternator or Separate Source functions.

#### **Configuring the Control Valve for No Hard Water Bypass Operation:**

Select *nHbP* for control operation. For no hard water bypass operation, the 3-wire communication cable is not used.

Selection requires that a connection to a MAV or a Clack no hard water bypass valve is made to the 2-pin connector labeled *MAV* located on the printed circuit board. If using a MAV, the A port of the MAV must be plugged and the B port connected to the valve outlet. When set to *nHbP*, the MAV will be driven closed before the first regeneration cycle that is not Fill, Softening, or Filtering and be driven open after the last regeneration cycle that is not Fill.

*Note:* If the control valve enters into an error state during regeneration, the no hard water bypass valve will return to the open position, if not already there.



#### **Configuring the Control Valve for Separate Source Operation:**

Select *SEPS* for control operation. For separate source operation, the 3-wire communication cable is not used.

Selection requires that a connection to a Clack motorized alternating valve (MAV) is made to the 2-pin connector labeled *MAV* located on the printed circuit board. The C port of the MAV must be connected to the valve inlet, the A port connected to the separate source used during regeneration, and the B port connected to the feed water supply.

When set to *SEPS*, the MAV will be driven closed before the first regeneration cycle and be driven open after the last regeneration cycle.

*Note:* If the control valve enters into an error state during regeneration mode, the MAV will return to the open position, if not already there.



#### **Configuring the Control Valve to Operate with Clack System Controller:**

Select *SYS* to link control valve to the Clack system controller. For communication between the control valve and the system controller, a 3-wire communication cable is required.

Selection requires that a connection to a Clack no hard water bypass (V3070FF or V3070FM) be made to the 2-pin connector labeled *MAV* located on the printed circuit board for WS1 and WS1.25 control valves. For valve types WS1.5 and WS2, a connection from a Clack no hard water bypass (V3097-BSPT or V3098-BSPT) to the 2-pin connector labeled *MAV* located on the printed circuit board is required.

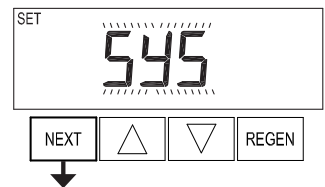



**Configuring the Control Valve to Act as an Alternator:**

Prior to starting the programming steps, connect the communication cable to each control valve board's 3-pin connector labeled <i>COMM CABLE</i> . Also connect the meter cord to either control valve to the 3-pin connector labeled <i>METER</i> .			
		Softener Valve Programming Steps	
Configuration Settings	Step 5CS	Set to <i>ALT A</i> Connect the outlet plumbing of ALT A valve to the MAV's A port and connect the MAV's 2-pin wire connector to the 2-pin connector labeled <i>DRIVE</i> on the ALT A valve.	Set to <i>ALT b</i> Connect the outlet plumbing of ALT b valve to the MAV's B port. No electrical connections are required between the ALT b valve and the MAV.
Softener System Setup	Step 6S	Set Ionic Capacity.	Set Ionic Capacity.
Softener System Setup	Step 7S	Set to <i>AUTO</i> .	Set to <i>AUTO</i> .
Softener System Setup	Step 8S	Set Regeneration Time Option to <i>on 0</i> .	Set Regeneration Time Option to <i>on 0</i> .
Installer Display Settings	Step 3I	Set Day Override to <i>oFF</i> .	Set Day Override to <i>oFF</i> .
If set up for a filter, set Volume Capacity in Step 4F; set Regeneration Time Option in Step 5F to <i>on 0</i> ; and set Day Override in Step 3I to <i>oFF</i> .			

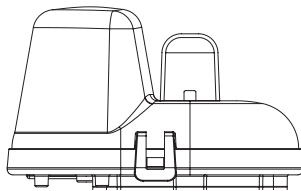

**Retracted**  
Valve A in Service Position = MAV piston rod retracted

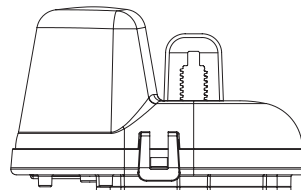

**Extended**  
Valve B in Service Position = MAV piston rod extended

**Clack Twin Alternator Operations:**

- Twin alternating systems can be programmed with a day override setting combined with the normal volume-based regeneration programming. A twin alternating system in this configuration will then regenerate based on the volume used or the day override if there is a period of low water usage.
- Twin alternating systems can be programmed as a time clock only based regenerating system. In this configuration, the days remaining are counted only on the unit that is in service. The unit in standby mode only notes days in diagnostics, which results in time clock only twin regeneration initiation.
- Twin alternating systems can be programmed for a delayed regeneration time. The system will allow an immediate transfer of the MAV to switch tanks and place a fully regenerated unit in service once a unit becomes exhausted. The exhausted unit will then be placed into standby mode and allowed to have a delayed regeneration at the pre-set time.

**WS1, WS1.25, and WS1.5 Valves**

For Clack alternator systems using WS1, WS1.25, and WS1.5 valves, there will be an option to delay the last 2 cycles of regeneration (Rinse and Fill). This feature splits the regeneration into 2 portions. The first portion of the regeneration will start immediately and all programmed cycles before Rinse and Fill will be performed. After all programmed cycles before Rinse and Fill are completed, the control valve will drive to the service position (displaying *Delayed Rinse + Fill Pending*). When the volume of the online unit is depleted to 10% of its programmed capacity, the control valve will be triggered to finish the second portion of the regeneration. Once Rinse and Fill cycles are complete, the valve will re-enter standby mode until requested to come online for service. Set to *oFF* to deactivate this feature.

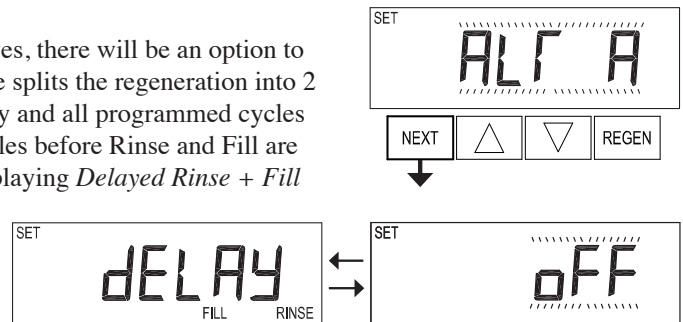

**WS2 Valve**

For Clack alternator systems using the WS2 valve, when NEXT is pressed after selecting *ALT A* or *ALT B*, a display will allow the user to set the length of pre-service rinse time for the standby tank just prior to returning to service. Set to *OFF* to deactivate this feature. With *1.0T* or *1.5T* set, the same display appears and is set in a similar manner.

*Note:* If the control valve is in an error state during regeneration mode, the MAV will close the B port and keep open the A port until the error is corrected and reset.

Press NEXT to go to Step 6CS. Press REGEN to return to previous step.

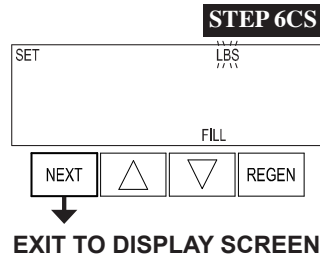
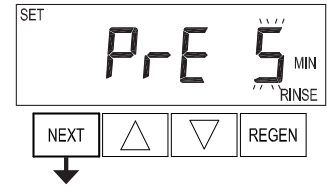
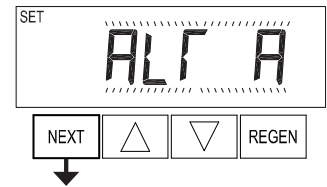

**Step 6CS – Fill Units:** If set as a softener, Step 2CS is set to *1.5* or *1.5T*, and Fill is part of the Regeneration Cycle Sequence, fill units of *MIN* or *LBS* can be selected. Press NEXT to exit OEM Configuration Setup. Press REGEN to return to previous step.



**EXIT TO DISPLAY SCREENS**

### OEM Softener System Setup

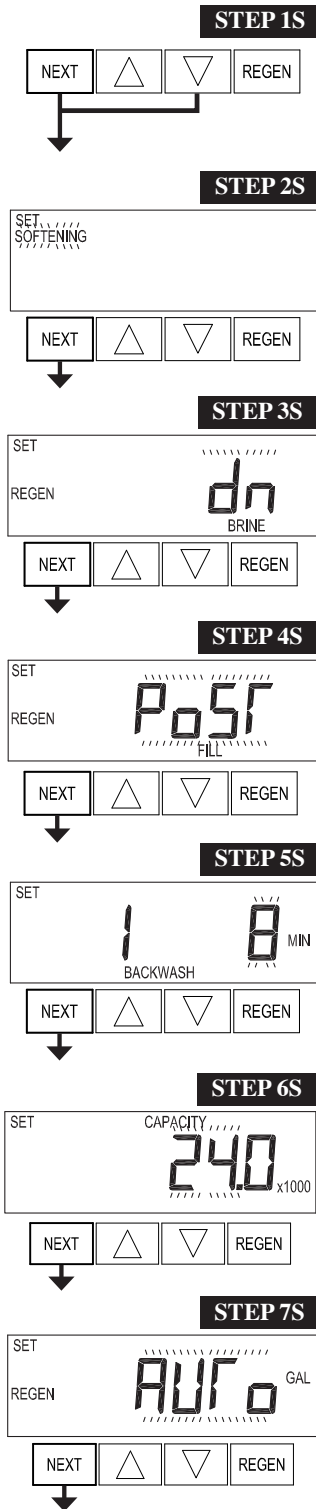

**Step 1S** – Press NEXT and ▼ simultaneously for 5 seconds and release. If screen in Step 2S does not appear, the lock on the valve is activated. To unlock, press ▼, NEXT, ▲, and REGEN in sequence, and try again.

**Step 2S** – Treatment Type: Use ▼ or ▲ to select *SOFTENING*. Press NEXT to go to Step 3S. Press REGEN to exit OEM Softener System Setup.

**Step 3S** – Brining Direction: Use ▼ or ▲ to select *UP* or *dn*. Prior to selecting the upflow regeneration cycle, verify that the correct body, main piston, regenerant piston, and stack are being used and that the injector plug(s) are in the correct location. Refer to the Service Manual for drawings and part numbers. Press NEXT to go to Step 4S. Press REGEN to return to previous step.

**Step 4S** – Refill Option: Use ▼ or ▲ to select one of the following options:

- *PoST*: The brine tank refills after the final rinse.
- *PrE*: The brine tank refills 4 hours before the regeneration time set.

Press NEXT to go to Step 5S. Press REGEN to return to previous step.

**Step 5S** – Cycle Durations: Use ▼ or ▲ to set the value for the first cycle. Value ranges and units will vary depending on the cycle, see Table 1 for more detail. Press NEXT to set the value for the next cycle. Repeat for all cycles. Once a value is set for all cycles, press NEXT to go to Step 6S. Press REGEN to return to previous step.

**Step 6S** – Ionic Capacity: Use ▼ or ▲ to set the ionic capacity. The ionic capacity is based on the volume of resin and LBS of salt fill previously selected. Press NEXT to go to Step 7S. Press REGEN to return to previous step.

**Step 7S** – Volume Capacity: Use ▼ or ▲ to select one of the following options:

- *Auto*: Capacity will be automatically calculated and reserve capacity will be automatically estimated.
- *oFF*: If this option is selected, regeneration trigger must be set in Step 7S(A).
- A number: Regeneration initiation will be based on the value specified (in gallons).

See Setting Options Table for more detail. Press NEXT to go to Step 8S. Press REGEN to return to previous step.

**STEP 7S(A)**

**Step 7S(A) – Regeneration Trigger:** Use ▼ or ▲ to select one of the following options:

- *28 day:* Regeneration will be triggered by Day Override set in Installer Settings.
- *7 day:* Regeneration will be triggered on specific days of the week.

This display will only appear if Step 7S is set to *oFF*. Press NEXT to go to Step 8S. Press REGEN to return to previous step.

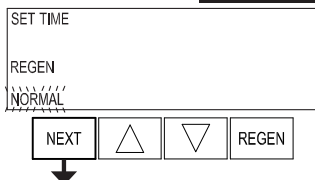
**STEP 8S**

**Step 8S – Regeneration Time Option:** Use ▼ or ▲ to select one of the following options:

- *NORMAL:* Regeneration will occur at the preset time.
- *on 0:* Regeneration will occur immediately when the volume capacity reaches 0 (zero).
- *NORMAL + on 0:* Regeneration will occur at one of the following:
  - the preset time when the volume capacity falls below the reserve or the specified number of days between regenerations is reached, whichever comes first; or
  - immediately after 10 minutes of no water usage when the volume capacity reaches 0 (zero).

This option will not be available if Step 5CS is set to *ALT A* or *ALT b* or if Step 2CS is set to *1.0T* or *1.5T*.

This display will not appear if Step 7S is set to *oFF* or if Step 5CS is set to *SYS*. See Setting Options Table for more detail.

Press NEXT to go to Step 9S. Press REGEN to return to previous step.

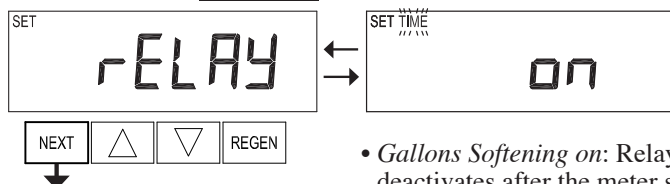
**STEP 9S**

**Step 9S – Relay Output:** Use ▼ or ▲ to select one of the following options:

- *Time on:* Relay activates a set time after the start of a regeneration and deactivates after a set period of time. The start of regeneration is defined as the first Backwash cycle, Dn Brine cycle, or UP Brine cycle whichever comes first.
- *Gallons Softening on:* Relay activates after a set volume has been used while in service and deactivates after the meter stops registering flow and the set time period has expired.
- *Gallons Softening Regen on:* Relay activates after a set volume has been used while in service or during regeneration and deactivates after the meter stops registering flow and the set time period has expired.
- *ERROR:* Relay closes whenever the valve enters an error state and immediately deactivates when the control exits the error state. Step 9S(A) and Step 9S(B) will not appear if this option is selected.
- *Off:* Feature not used. Step 9S(A) and Step 9S(B) will not appear if this option is selected. Press NEXT to go to Step 9S(A). Press REGEN to return to previous step.

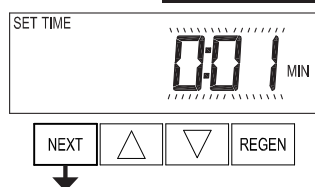
**STEP 9S(A)**

**Step 9S(A) – Relay Setpoint Actuation:** Use ▼ or ▲ to select one of the following options:

- *Relay Actuation Time:* Set the length of time after the start of regeneration prior to relay activation (Range: 1 second – 200 minutes). The start of regeneration is defined as the first Backwash cycle, Dn Brine cycle, or UP Brine cycle, whichever comes first.
- *Relay Actuation Gallons:* Set the number of gallons that will be treated prior to replay activation (Range: 1 – 200).

Press NEXT to go to Step 9S(B). Press REGEN to return to previous step.

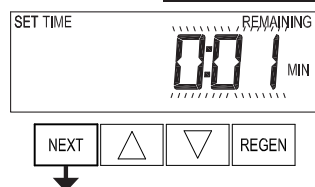
**STEP 9S(B)**

**Step 9S(B) – Relay Duration:** Use ▼ or ▲ to set the length of time the relay will stay active prior to deactivation. If Step 10S is set to *Time on*, value range is 1 second – 200 minutes. If Step 9S is set to *Gallons Softening on* or *Set Gallons Softening Regen on*, value range is 1 second – 20 minutes.

Press NEXT to exit OEM Softener System Setup. Press REGEN to return to previous step.

**EXIT OEM SOFTENER SYSTEM SETUP**

## Setting Options Table

Filters should only use shaded options

Volume Capacity	Regeneration Time Option	Day Override	Result <sup>1</sup>
AUTO	NORMAL	oFF	Reserve capacity automatically estimated. Regeneration occurs at the next regeneration time when volume capacity falls below the reserve capacity.
AUTO	NORMAL	Any number	Reserve capacity automatically estimated. Regeneration occurs at the next regeneration time when volume capacity falls below the reserve capacity or the specified number of days between regenerations is reached, whichever comes first.
Any number	NORMAL	oFF	Reserve capacity <u>not</u> automatically estimated. Regeneration occurs at the next regeneration time when volume capacity reaches 0.
oFF	NORMAL (not adjustable)	Any number	Reserve capacity <u>not</u> automatically estimated. 28 day: Regeneration occurs at the next regeneration time when the specified number of days between regenerations is reached. 7 day: Regeneration will occur on the day(s) of the week set in Installer Settings.
Any number	NORMAL	Any number	Reserve capacity <u>not</u> automatically estimated. Regeneration occurs at the next regeneration time when volume capacity reaches 0 or the specified number of days between regenerations is reached, whichever comes first.
AUTO	On 0	oFF	Reserve capacity automatically estimated. Regeneration occurs immediately when volume capacity reaches 0. Time of regeneration will not be allowed to be set because regeneration will always occur when volume capacity reaches 0.
Any number	On 0	oFF	Reserve capacity <u>not</u> automatically estimated. Regeneration occurs immediately when volume capacity reaches 0.
AUTO	NORMAL + on 0	oFF	Reserve capacity automatically estimated. Regeneration occurs at the next regeneration time when volume capacity falls below the reserve capacity, or regeneration occurs after 10 minutes of no water usage when volume capacity reaches 0.
AUTO	NORMAL + on 0	Any number	Reserve capacity automatically estimated. Regeneration occurs at the next regeneration time when volume capacity falls below the reserve capacity or the specified number of days between regenerations is reached, or regeneration occurs after 10 minutes of no water usage when volume capacity reaches 0.
Any number	NORMAL + on 0	Any number	Reserve capacity <u>not</u> automatically estimated. Regeneration occurs at the next regeneration time when the specified number of days between regenerations is reached, or regeneration occurs after 10 minutes of no water usage when volume capacity reaches 0.

<sup>1</sup> Reserve Capacity estimate is based on history of water usage. Reserve capacity estimate is not available with alternator systems or twin tank valves.

### OEM Filter System Setup

**STEP 1F**



**Step 1F** – Press NEXT and ▼ simultaneously for 5 seconds and release. If screen in Step 2CS does not appear, the lock on the valve is activated. To unlock, press ▼, NEXT, ▲, and REGEN in sequence, and try again.

**STEP 2F**

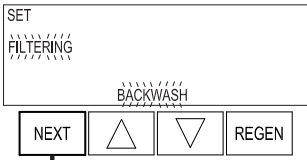

**Step 2F** – Treatment Type: Use ▼ or ▲ to select *FILTERING BACKWASH* or *FILTERING REGEN* (see table). Press NEXT to go to Step 3F. Press REGEN to exit OEM Filter System Setup.



**STEP 3F**

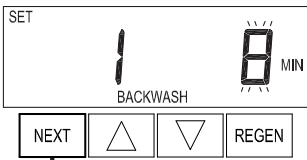

**Step 3F** – Cycle Durations: Use ▼ or ▲ to set the value for the first cycle. Value ranges and units will vary depending on the cycle, see Table 1 for more detail. Press NEXT to set the value for the next cycle. Repeat for all cycles. Once a value is set for all cycles, press NEXT to go to Step 4F. Press REGEN to return to previous step.

**STEP 4F**

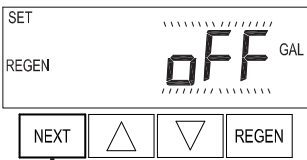

**Step 4F** – Volume Capacity: Use ▼ or ▲ to select one of the following options:

- *oFF*: If this option is selected, regeneration trigger must be set in Step 4F(A).
- A number: Regeneration initiation will be based on the value specified (in gallons). See Setting Options Table for more detail.

Press NEXT to go to Step 4F(A). Press REGEN to return to previous step.

**STEP 4F(A)**

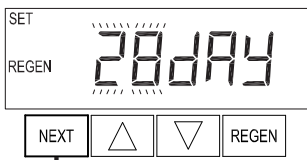

**Step 4F(A)** – Regeneration Trigger: Use ▼ or ▲ to select one of the following options:

- *28 day*: Regeneration will be triggered by Day Override set in Installer Settings.
- *7 day*: Regeneration will be triggered on specific days of the week.

This display will only appear if Step 4F is set to *oFF*. Press NEXT to go to Step 5F. Press REGEN to return to previous step.



**STEP 5F**

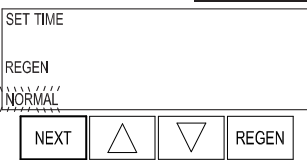

**Step 5F** – Regeneration Time Option: Use ▼ or ▲ to select one of the following options:

- *NORMAL*: Regeneration will occur at the preset time.
- *on 0*: Regeneration will occur immediately when the volume capacity reaches 0 (zero).
- *NORMAL + on 0*: Regeneration will occur at one of the following:
  - the preset time when the volume capacity falls below the reserve or the specified number of days between regenerations is reached, whichever comes first; or
  - immediately after 10 minutes of no water usage when the volume capacity reaches 0 (zero).

This option will not be available if Step 5CS is set to *ALT A* or *ALT b* or if Step 2CS is set to *1.0T* or *1.5T*.

This display will not appear if Step 4F is set to *oFF* or if Step 5CS is set to *SYS*. See Setting Options Table for more detail. Press NEXT to go to Step 6F. Press REGEN to return to previous step.

**STEP 6F**

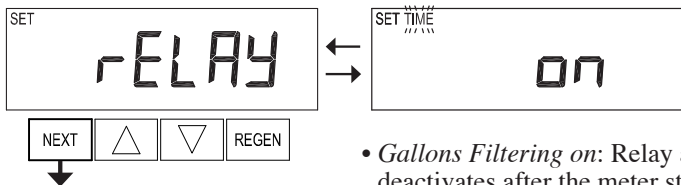

**Step 6F – Relay Output:** Use ▼ or ▲ to select one of the following options:

- *Time on:* Relay activates a set time after the start of a regeneration and deactivates after a set period of time. The start of regeneration is defined as the first Backwash cycle or Dn Brine cycle, whichever comes first.

- *Gallons Filtering on:* Relay activates after a set volume has been used while in service and deactivates after the meter stops registering flow and the set time period has expired.
- *Gallons Filtering Regen on:* Relay activates after a set volume has been used while in service or during regeneration and deactivates after the meter stops registering flow and the set time period has expired.
- *ERROR:* Relay closes whenever the valve enters an error state and immediately deactivates when the control exits the error state. Step 6F(A) and Step 6F(B) will not appear if this option is selected.
- *Off:* Feature not used. Step 6F(A) and Step 6F(B) will not appear if this option is selected. Press NEXT to go to Step 6F(A). Press REGEN to return to previous step.

**STEP 6F(A)**

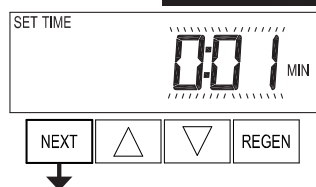

**Step 6F(A) – Relay Setpoint Actuation:** Use ▼ or ▲ to select one of the following options:

- *Relay Actuation Time:* Set the length of time after the start of regeneration prior to relay activation (Range: 1 second – 200 minutes). The start of regeneration is defined as the first Backwash cycle or Dn Brine cycle, whichever comes first.
- *Relay Actuation Gallons:* Set the number of gallons that will be treated prior to replay activation (Range: 1 – 200).

Press NEXT to go to Step 6F(B). Press REGEN to return to previous step.

**STEP 6F(B)**

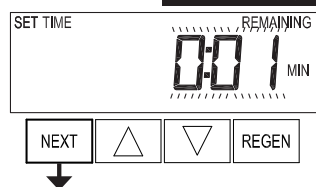

**Step 6F(B) – Relay Duration:** Use ▼ or ▲ to set the length of time the relay will stay active prior to deactivation. If Step 6F is set to *Time on*, value range is 1 second – 200 minutes. If Step 6F is set to *Gallons Filtering on* or *Set Gallons Filtering Regen on*, value range is 1 second – 20 minutes.

Press NEXT to exit OEM Filter System Setup. Press REGEN to return to previous step.

**EXIT OEM FILTER SYSTEM SETUP**

## Installer Display Settings: 7 Day Regeneration

*Note:* These displays will only appear if Volume Capacity is set to *oFF* and Regeneration Trigger is set to *7 day*.

### STEP 1I

**Step 1I** – Press NEXT and ▲ simultaneously for about 5 seconds and release.

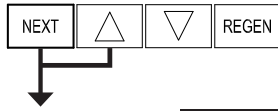

### STEP 2I

**Step 2I** – Current Day: Use ▼ or ▲ to set the current day of the week:

- 1: Sunday
- 2: Monday
- 3: Tuesday
- 4: Wednesday
- 5: Thursday
- 6: Friday
- 7: Saturday

Press NEXT to go to Step 3I. Press REGEN to exit Installer Display.

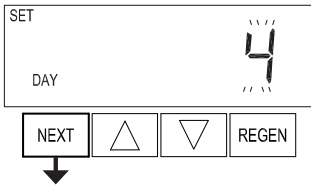

### STEP 3I

**Step 3I** – Regeneration Days: Use ▼ or ▲ to turn regeneration *on* or *oFF* for day 1 (Sunday).

Press NEXT to advance to day 2. Repeat for each day of the week.

After completing day 7, press NEXT to go to Step 4I. Press REGEN to go to previous display.

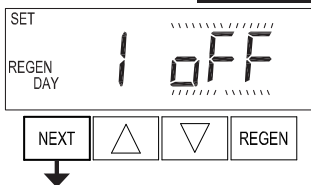

### STEP 4I

**Step 4I** – Next Regeneration Time: Use ▼ or ▲ to set the hour of day for regeneration. The default time is 2:00. Press NEXT to set the minutes.

Once the minutes are set, press NEXT to go to exit Installer Display Settings. Press REGEN to return to previous step.



**EXIT INSTALLER DISPLAY SETTINGS**



### Installer Display Settings: 28 Day Regeneration / Auto

Note: These displays will only appear if Volume Capacity is set to anything other than *oFF* or if Regeneration Trigger is set to 28 day.

**STEP 1I**

**Step 1I** – Press NEXT and ▲ simultaneously for about 5 seconds and release.

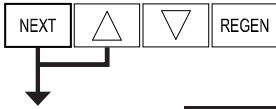

**STEP 2I**

**Step 2I** – Hardness: Use ▼ or ▲ to set the amount of influent hardness.

This display will only appear if Step 7S is set to *Auto*.

Press NEXT to go to Step 3I. Press REGEN to exit Installer Display Settings.

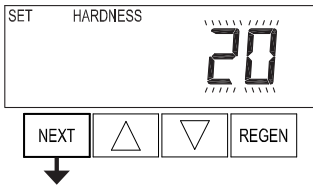

**STEP 3I**

**Step 3I** – Day Override: When Regeneration Trigger is set to 28 day, sets the number of days between regenerations. When Volume Capacity is set to *Auto* or a number, sets the maximum number of days between regenerations. Use ▼ or ▲ to select one of the following options:

- A number (1 – 28): Regeneration will be called for every set number of days even if sufficient volume of water was not used to call for a regeneration.
- *oFF*: Regeneration initiation is based solely on volume used.

See Setting Options Table for more detail on setup.

Press NEXT to go to Step 4I. Press REGEN to return to previous step.

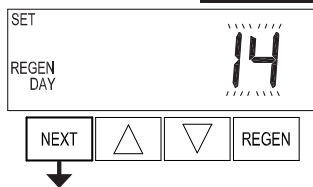

**STEP 4I**

**Step 4I** – Next Regeneration Time: Use ▼ or ▲ to set the hour of day for regeneration. The default time is 2:00. This display will show *REGEN on 0 GAL* if Regeneration Time Option is set to *on 0*. Press NEXT to set the minutes.

Once the minutes are set, press NEXT to exit Installer Display Settings. Press REGEN to return to previous step.

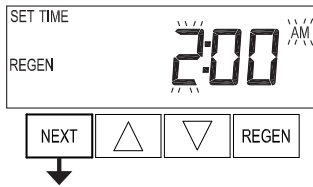

**EXIT INSTALLER DISPLAY SETTINGS**

## Diagnostics

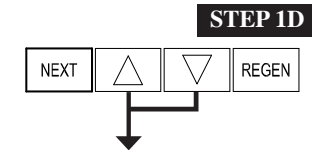

**Step 1D** – Press ▼ and ▲ simultaneously for 5 seconds and release. If screen in Step 2D does not appear, the lock on the valve is activated. To unlock, press ▼, NEXT, ▲, and REGEN in sequence, and try again.

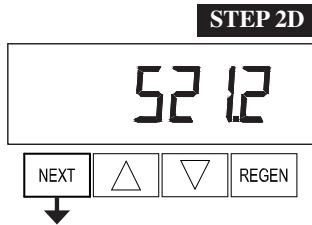

**Step 2D** – Software Version.  
Press NEXT to go to Step 3D. Press REGEN to exit Diagnostics.

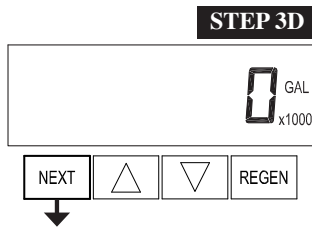

**Step 3D** – Total Volume Used Since Startup: This display will show zero if a water meter is not installed.  
Press NEXT to go to Step 4D. Press REGEN to return to previous step.

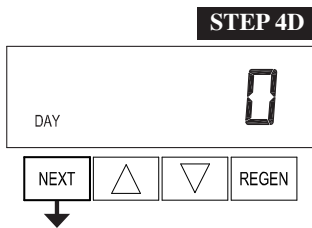

**Step 4D** – Total Days Since Startup.  
Press NEXT to go to Step 5D. Press REGEN to return to previous step.

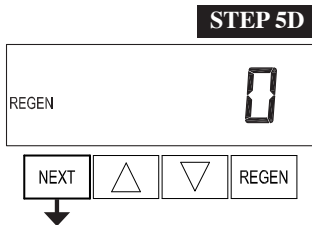

**Step 5D** – Total Regenerations Since Startup.  
Press NEXT to go to Step 6D. Press REGEN to return to previous step.

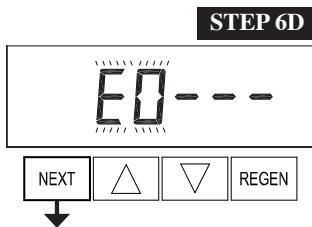

**Step 6D** – Error Log: Use ▼ or ▲ to scroll through the last 10 errors generated by the control during operation.  
Press NEXT to go to Step 7D. Press REGEN to return to previous step.

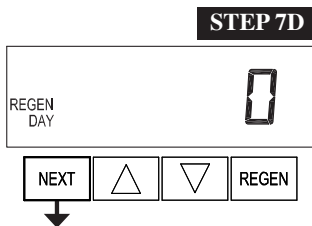

**Step 7D** – Days Since Last Regeneration.  
Press NEXT to go to Step 8D. Press REGEN to return to previous step.

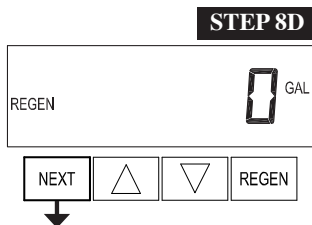

**Step 8D** – Volume Since Last Regeneration: This display will show zero when a water meter is not installed.  
Press NEXT to go to Step 9D. Press REGEN to return to previous step.

**STEP 9D**

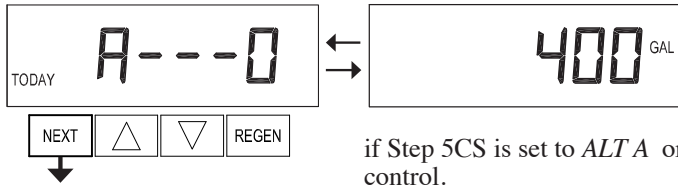

**Step 9D – Reserve History, Last 7 Days:** If the valve is set up as a softener, a meter is installed, and Volume Capacity is set to *AUTO*, this display shows the reserve capacity for each of the last 7 days. Use ▼ or ▲ to scroll. Day 0 is today, day 1 is yesterday, etc.

This display will not appear if Step 2CS is set to *1.0T* or *1.5T*, if Step 5CS is set to *ALTA* or *ALT b*, or anytime the reserve capacity is not determined by the control.

Press NEXT at any time to go to Step 10D. Press REGEN to return to previous step.

**STEP 10D**

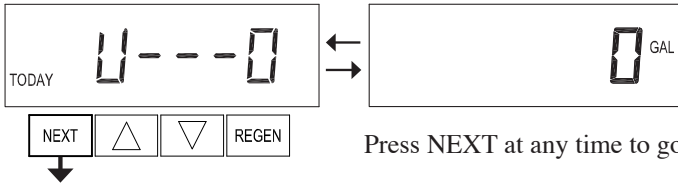

**Step 10D – Usage History, Last 63 Days:** This display shows the volume of water treated on each of the last 63 days. Use ▼ or ▲ to scroll. Day 0 is today, day 1 is yesterday, etc. If a regeneration occurred on the day, the word *REGEN* will also be displayed. This display will show dashes if a water meter is not installed.

Press NEXT at any time to go to Step 11D. Press REGEN to return to previous step.

**STEP 11D**

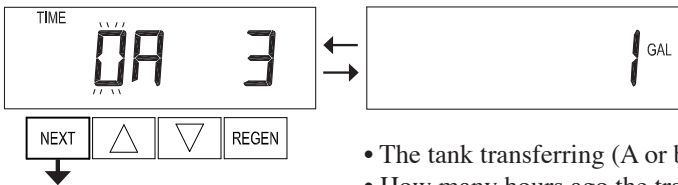

**Step 11D – Twin Tank Transfer History:** This display will only appear if Step 2CS is set to *1.0T* or *1.5T*. Use ▼ or ▲ to scroll through the last 10 tank transfers. This display shows, from left to right:

- The transfer number (0 – 9) with 0 being the most recent transfer.
  - The tank transferring (A or b).
  - How many hours ago the transfer occurred (999 hour maximum).
- The display alternates with the volume that was treated before the tank transferred. Press NEXT at any time to go to Step 12D. Press REGEN to return to previous step.

**STEP 12D**

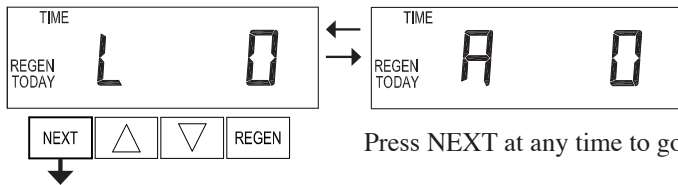

**Step 12D – MAV Drive History (Retracted):** This display shows the history of MAV output to drive the piston rod into the valve. This display will only appear if the MAV Output is active. *L* is the latest drive time and *A* is the average drive time. Drive time is measured in 1/100 of a second, meaning a 17.10 second move is displayed as *1710*.

Press NEXT at any time to go to Step 13D. Press REGEN to return to previous step.

Press and hold ▼ and ▲ for 3 seconds while in Step 12D to reset the MAV Drive History in both the retracted and extended piston rod position. To view the old MAV drive history data for retracted and extended rod position, press and hold REGEN and ▲ while in Step 12D. Press NEXT to advance display to the old MAV drive history.

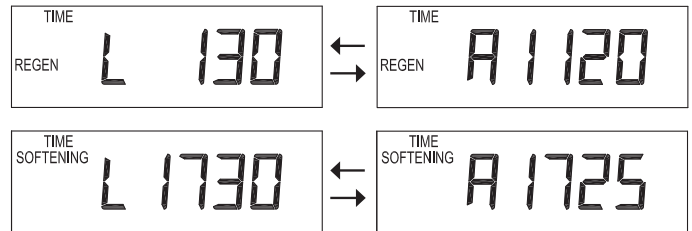

**STEP 13D**

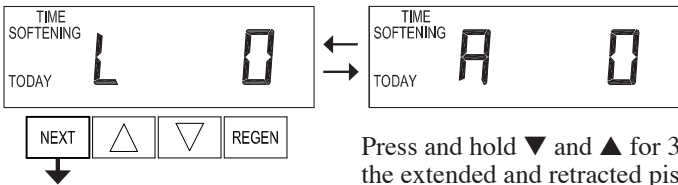

**Step 13D – MAV Drive History (Extended):** This display shows the history of MAV output to drive the piston rod out of the valve. This display will only appear if the MAV Output is active. *L* is the latest drive time and *A* is the average drive time. Drive time is measured in 1/100 of a second, meaning a 17.10 second move is displayed as *1710*.

Press and hold ▼ and ▲ for 3 seconds while in Step 13D to reset the MAV drive history in both the extended and retracted piston rod position. To view the old MAV drive history data, see Step 12D.

Press NEXT at any time exit Diagnostics. Press REGEN to return to previous step.

**EXIT DIAGNOSTICS**









## Revision History:

**2/21/2022**

**PAGE 4:**

4	V3408EE-05BOARD	WS1THRU2 EE PCB 20PIN REPLC	1
---	-----------------	-----------------------------	---

Updated board drawing

**PAGE 5:**

Updated Regeneration Cycle and Times table

**PAGE 8:**

The Control Valve to operate as a Progressive Flow System; or

**PAGE 11:**

Steps 5S-8S - Remove “For valve types 1.5 and 2.0, “oFF” is also available”

**PAGE 12:**

Step 9S - Remove “For valve types 1.5 and 2.0, “oFF” is also available”

**PAGE 10:**

Add progressive flow instructions

**PAGE 15:**

Remove 30-second backwash step

**PAGE 20:**

Update software version

**1/18/2024**

**PAGE 4:**

3	V3002	WS1 DRIVE BRACKET ASY W/ MOTOR	1
---	-------	--------------------------------	---

Updated drawing

We recommend that each externally wired relay contain a suppressor diode, which is normally placed across the relay coil in order to protect the control against back EMF at relay coil deactivation.

**PAGE 8:**

Add 1.5T instructions

Remove progressive flow instructions

Various grammatical and formatting changes throughout